

**SERIES 14**  
**Short stroke cylinder**  
**Double effect**

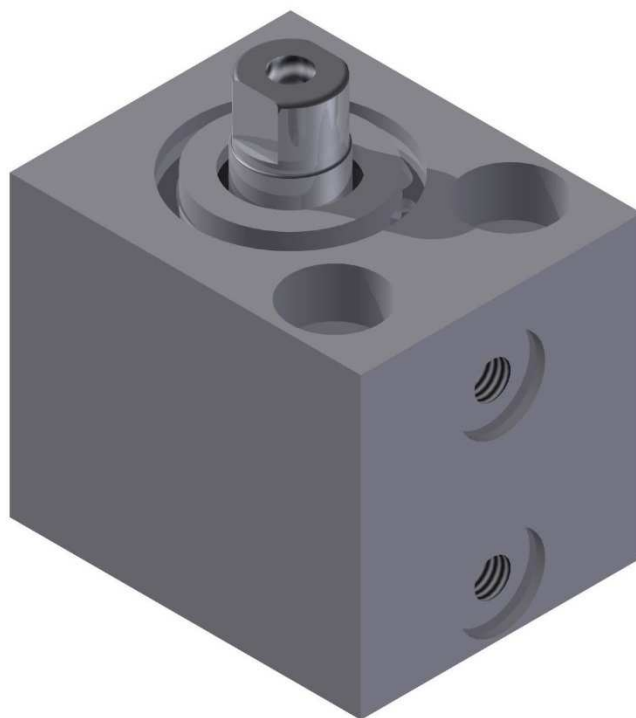

Technical characteristics	
<b>Design type</b>	Short stroke cylinder Cylinder can be repaired easily.
<b>Function</b>	Double effect
<b>Piston diameter in mm</b>	12, 16, 20, 25
<b>Stroke in mm</b>	10
<b>Pneumatic connection</b>	M5, G1/8
<b>Installation position</b>	Any
<b>Temperature range</b>	-20°C to +80°C
<b>Materials</b>	- Piston rod from stainless steel - Cylinder housing from aluminium, anodised
<b>Seals</b>	- Perbunan
<b>Damping</b>	Without damping
<b>Other</b>	- Magnetic pistons upon request - Heat-resistant seals upon request - Customer-specific solutions upon request - Seal kits upon request
Pneumatic parameters	
<b>Medium</b>	Compressed air quality: 2.2.1 compliant with ISO 8573-1 (2=particle / 2=dew point / 1=oil concentration)
<b>Operating pressure in bar</b>	1 to 10

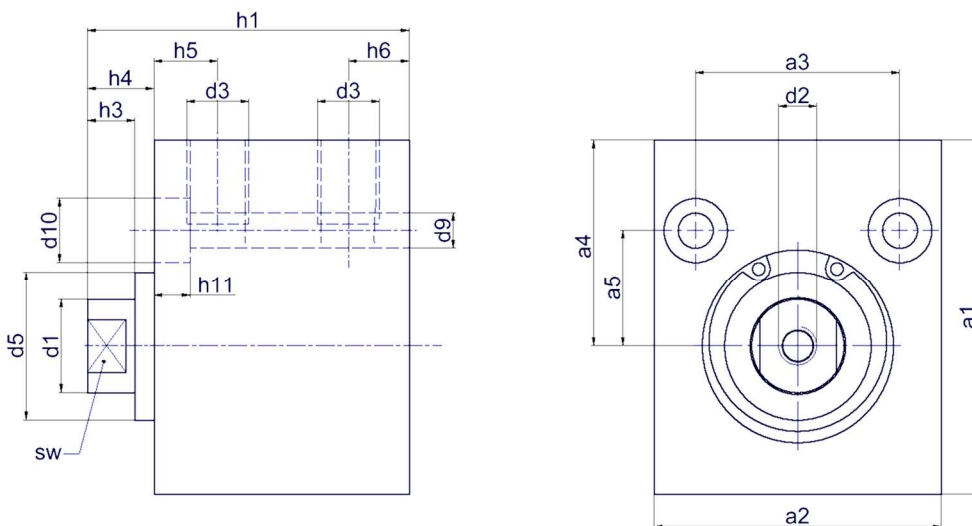
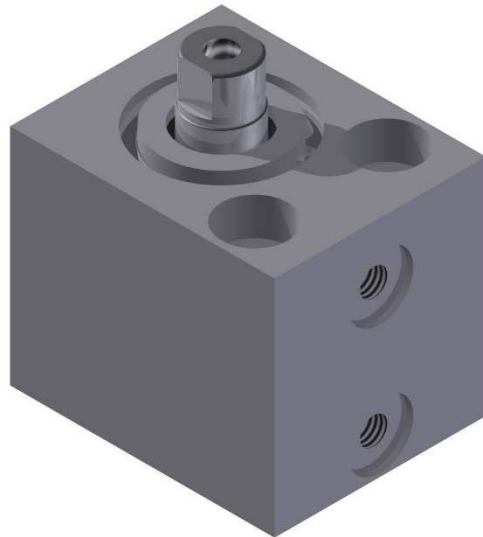

Part no.	Piston Ø	Stroke	d1 Ø	d2	d3	d5 Ø	d9 Ø	d10 Ø	h1	h3	h4	h5	h6
00010-55	12	10	5	-	M5	9	3.4	6	41	9	10	7	7
00018-44	16	10	8	M5	M5	11	5.5	10	41	7	10	9	6
00018-42	20	10	10	M5	M5	15	5.5	10	44	7	10	9	6
00018-43	25	10	15	M6	G1/8	23	5.5	10	50	7	10	10	9.5

Part no.	Piston Ø	h11	a1	a2	a3	a4	a5	sw
00010-55	12	3.4	25	20	13	16	9	-
00018-44	16	5.7	40	32	20	24	15	-
00018-42	20	5.7	40	32	20	24	15	8
00018-43	25	5.7	55	45	32	32	18	12